

Cylinder Equipment



Cylinder Carts Series 860

These cylinder carts are designed for the safe storage and transport of compressed gas cylinders. Carts are constructed of heavy 11-gauge steel to provide many years of reliable service. A pair of 1.5" polypropylene straps with steel cinch buckles is provided to hold each cylinder up to 12" in diameter securely in place. Carts have a convenient push handle and 4" swivel casters for easy maneuverability. The lowslung deck provides for easy loading and unloading of cylinders without lifting. Units are shipped unassembled.

Model	Description	Dimensions	Weight
864	Four cylinder wheeled cart	31"L x 24W" x 40H	130 lbs
866	Six cylinder wheeled cart	72L x 24W x 52 H	140 lbs



Cylinder Floor Stands Series 465

Available in two and three cylinder models, these floor stands are designed and built to provide safe storage of compressed gas cylinders with diameters up to 12" when a wall, post or bench is not available to secure the cylinder. Fully welded construction from 11 gauge and heavier plate steel and a quality epoxy powder paint finish provide structural integrity and long service life. Surfaces coming in contact with the cylinders are protected with vinyl edge guards. Cylinders are held securely in place with 1.5" polypropylene straps with steel cinch buckles.



Model	Description	Dimensions	Weight
465-2	Two cylinder floor stand	28" W x 30" H x 12" D	41 lbs
465-3	Three cylinder floor stand	40" W x 30" H x 12" D	56 lbs

Cylinder Equipment



Cylinder Storage Racks Series 490

FEATURES

- Safe cylinder restraint
- Organized gas cylinder storage
- Simple installation
- Uses space efficiently
- Removable and relocatable

DESCRIPTION

The storage of compressed gas cylinders to comply with Federal, State and Local regulations often presents a number of problems. These new cylinder storage racks can help organize your cylinder storage and help you comply with the myriad of regulations. Because the frame is predrilled to accommodate anchoring the rack to the floor they are ideal for situations where cylinder must be located away from a wall or other securing fixture.

Racks are available in standard sizes to hold one to nine cylinders. Custom racks are available. Standard rack configurations are shown below.

The unique modular design of welded square steel tubing (2" x 2") components bolted together to form the frame provides the rigidity necessary to allow the frame to be constructed without a bottom. This allows cylinders to be rolled into the frame without lifting. Racks are provided with either single or dual restraint steel chains to secure the cylinders. Single restraint racks secure the individual cylinders with a chain for each cylinder located at the top of the rack. Dual restraint models have a set of chains for each cylinder at 15" and 30" from the floor. Racks are painted with black industrial enamel to provide long lasting protection. Some assembly is required.

These cylinder storage racks meet the requirements of the National Fire Protection Association, National Fire Codes, Uniform Fire Codes, Uniform Building Codes and Seismic Zone 4 Restraint Regulations, Compressed Gas Association, and OSHA.

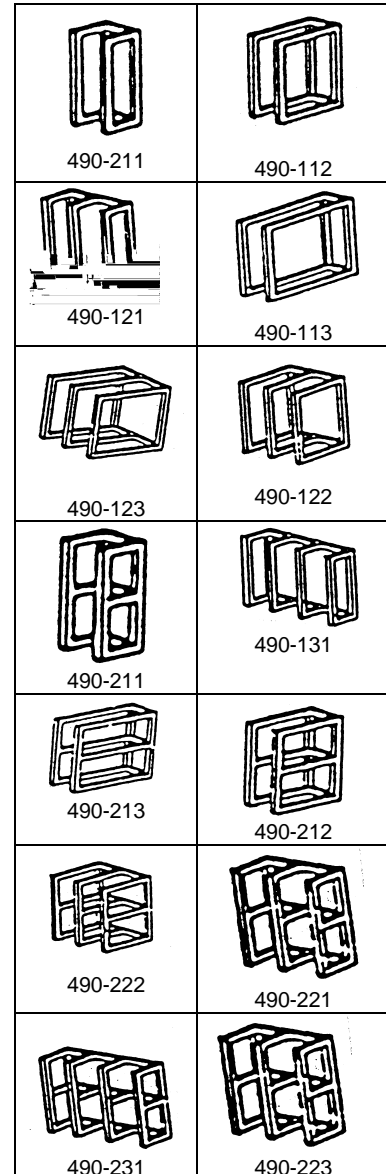
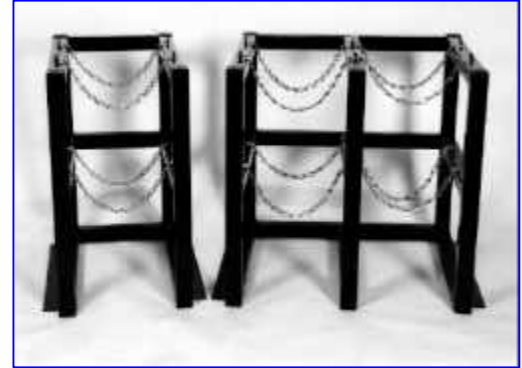

Model	Description	Nominal Dimensions
Single restraint models		
490-111	1 cyl wide x 1 cyl deep	12" W x 12" D x 30" H
490-121	2 cyl wide x 1 cyl deep	24" W x 12" D x 30" H
490-131	3 cyl wide x 1 cyl deep	36" W x 12" D x 30" H
490-112	1 cyl wide x 2 cyl deep	12" W x 24" D x 30" H
490-122	2 cyl wide x 2 cyl deep	24" W x 24" D x 30" H
490-132	3 cyl wide x 2 cyl deep	36" W x 24" D x 30" H
490-113*	1 cyl wide x 3 cyl deep	12" W x 36" D x 30" H
490-123*	2 cyl wide x 3 cyl deep	24" W x 36" D x 30" H
490-133*	3 cyl wide x 3 cyl deep	36" W x 36" D x 30" H
Dual Restraint Models		
490-211	1 cyl wide x 1 cyl deep	12" W x 12" D x 30" H
490-221	2 cyl wide x 1 cyl deep	24" W x 12" D x 30" H
490-231	3 cyl wide x 1 cyl deep	36" W x 12" D x 30" H
490-212	1 cyl wide x 2 cyl deep	12" W x 24" D x 30" H
490-222	2 cyl wide x 2 cyl deep	24" W x 24" D x 30" H
490-232	3 cyl wide x 2 cyl deep	36" W x 24" D x 30" H
490-213*	1 cyl wide x 3 cyl deep	12" W x 36" D x 30" H
490-223*	2 cyl wide x 3 cyl deep	24" W x 36" D x 30" H
490-233*	3 cyl wide x 3 cyl deep	36" W x 36" D x 30" H

*Cannot be shipped via UPS; must ship motor freight

"GAS STATION" PROCESS STANDS Series 495

DESCRIPTION

There are many situations where it would be more convenient to locate gas cylinders and distribution systems near the process, but away from a wall or other secure fixture. The "Gas Station" solves this problem. It can be located in any open area and support two or three cylinders and the associated gas distribution equipment. The stand is secured to the floor with bolts through the four pre-drilled holes provided in the base. Cylinders sit on the base plate and are securely held to the 2"x 2" square tubular steel frame painted gray with sturdy nylon belts. A changeover manifold or other distribution equipment can be conveniently mounted to the plate above the cylinders.

Model	Description	Dimensions	Weight
495-2	Two Cylinder Gas Station	28" W x 72 1/2" H x 12" D	56 lbs
495-3	Three Cylinder Gas Station	40" W x 72" H x 12" D	78 lbs

